

---

---

# DMX FX-15™ SWITCH PACK

## Operating Instructions

---

---

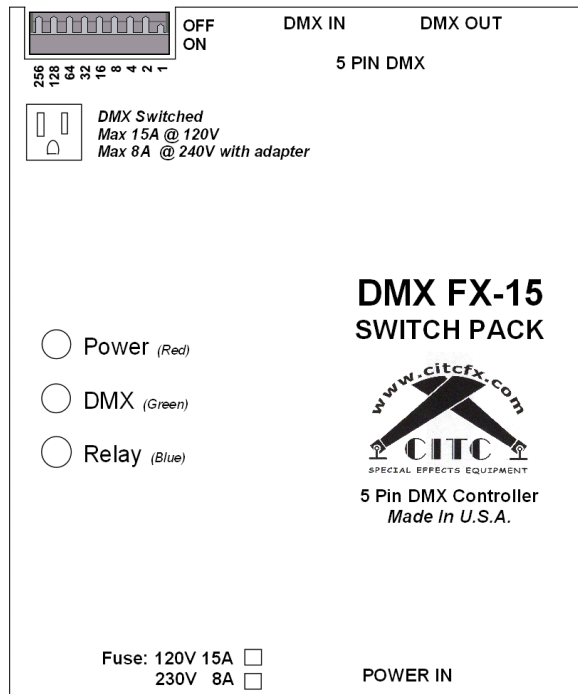

**P/N 250051 (120V)**

**P/N 205052 (230V)**

**Thank you for purchasing this DMX FX-15™ Switch Pack!**

- **To ensure proper operation of this unit, please take some time to read the manual carefully.**
- **We believe you will enjoy years of great service if you properly care for your new DMX FX-15™ Switch Pack.**

**CITC**  
1420 80th St. SW #D  
Everett, WA 98203  
**(888) 786-CITC**  
**[www.citcfx.com](http://www.citcfx.com)**



# Contents

<b>1. Equipment Supplied</b>	<b>3</b>
<b>2. Accessories</b>	<b>3</b>
<b>3. Description</b>	<b>4</b>
<b>4. Safety Instructions</b>	<b>4</b>
<b>5. Operating the DMX FX-15™ Switch Pack</b>	<b>4</b>
<b>5.1 Selecting The Location</b>	<b>4</b>
<b>5.2 Electrical Power Requirements</b>	<b>4</b>
<b>5.3 Hooking Things Up</b>	<b>4</b>
<b>5.4 Parts Location</b>	<b>5</b>
<b>5.5 Setting The DMX Address</b>	<b>6</b>
<b>5.6 Operation</b>	<b>6</b>
<b>5.7 Indicator Lights (LED)</b>	<b>7</b>
<b>5.8 Troubleshooting</b>	<b>7</b>
<b>6. Technical Data</b>	<b>7</b>
<b>7. Limited Warranty Conditions</b>	<b>8-9</b>

## **1. Equipment Supplied**

- **DMX FX-15™ Switch Pack**
- **Power Cord**
  - **120V (14 Gauge)**
  - **230V (16 Gauge)**
- **Instruction Booklet & Warranty Card**
- **Universal Plug Adapter (230V Only)**

## **2. Accessories**

- **Hanging Bracket w/ Safety Cable**
- **C-Clamp**
- **DMX Cables**
- **Spare Fuses**

**Please check whether all the products you ordered are supplied.**



### 3. Description of the DMX FX-15™ Switch Pack

The DMX FX-15™ Switch Pack is CITC's newest innovation allowing you to add DMX **ON/OFF** control to a multitude of equipment. Its compact and rugged design offers an amazing 15 amps of control on 120V and 8 amps on 230V.

### 4. Safety Instructions

**WARNING: Read and understand all labels and operating instructions before attempting installation.**

- No user serviceable parts. Taking apart the DMX FX-15™ will void your warranty.
- **RISK OF ELECTRICAL SHOCK-** This device is supplied with a grounding conductor. To reduce risk of electrical shock, connect only to properly grounded, grounding type receptacles. Never remove the third prong from the plug.
- If you have any doubts about the capacity or grounding of your existing circuits, consult a qualified electrician.
- Do not operate or store in wet locations.

### 5. Operating the DMX FX-15™ Switch Pack

#### 5.1 Selecting The Location

Secure dry location.

#### 5.2 Electrical Power Requirements

Be sure to use a **NON DIMMABLE** circuit that can provide 15 amps at 120Vac or 8 amps at 230Vac depending on which model you have purchased.

#### 5.3 Hooking Things Up

Plug the included power cord with female IEC connector into the "POWER IN" receptacle. The opposite end needs to be plugged into an appropriate "non dim" power source. Once the DMX FX-15™ is plugged in, the RED power light will illuminate. Connect the DMX cable to the DMX IN XLR connector. If a DMX-512 signal is present, the green LED will illuminate. You can now set the DMX address using the pins described in Section 5.4.

## 5.4 Parts Location

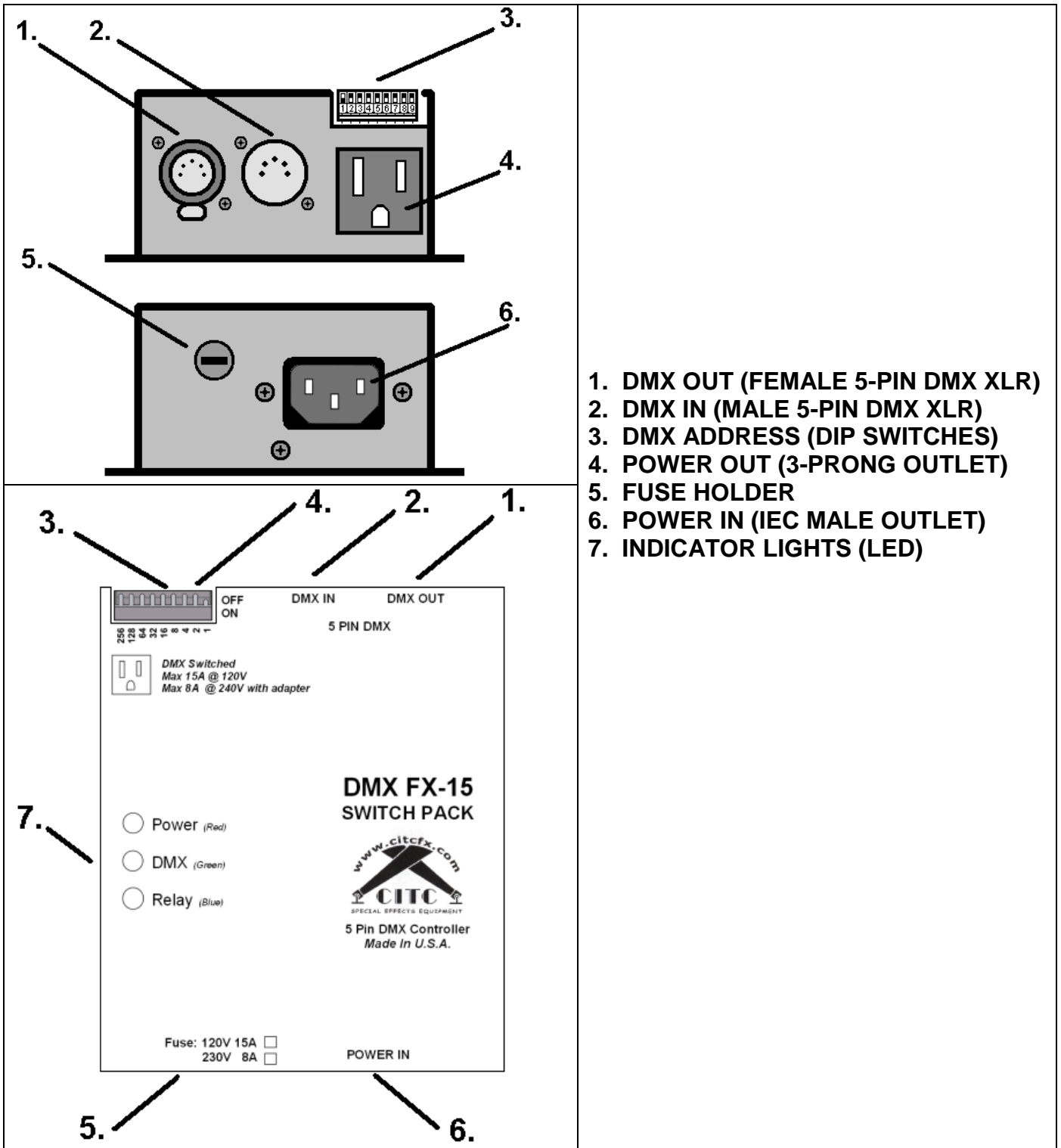

## 5.5 Setting The DMX Address

- The DMX FX-15™ can be addressed to any DMX channel from 1 to 511.
- The DMX FX-15™ occupies just one channel of DMX to operate.
- The DMX FX-15™ Switch Pack will not operate when all nine dip switches are in the “OFF” position.

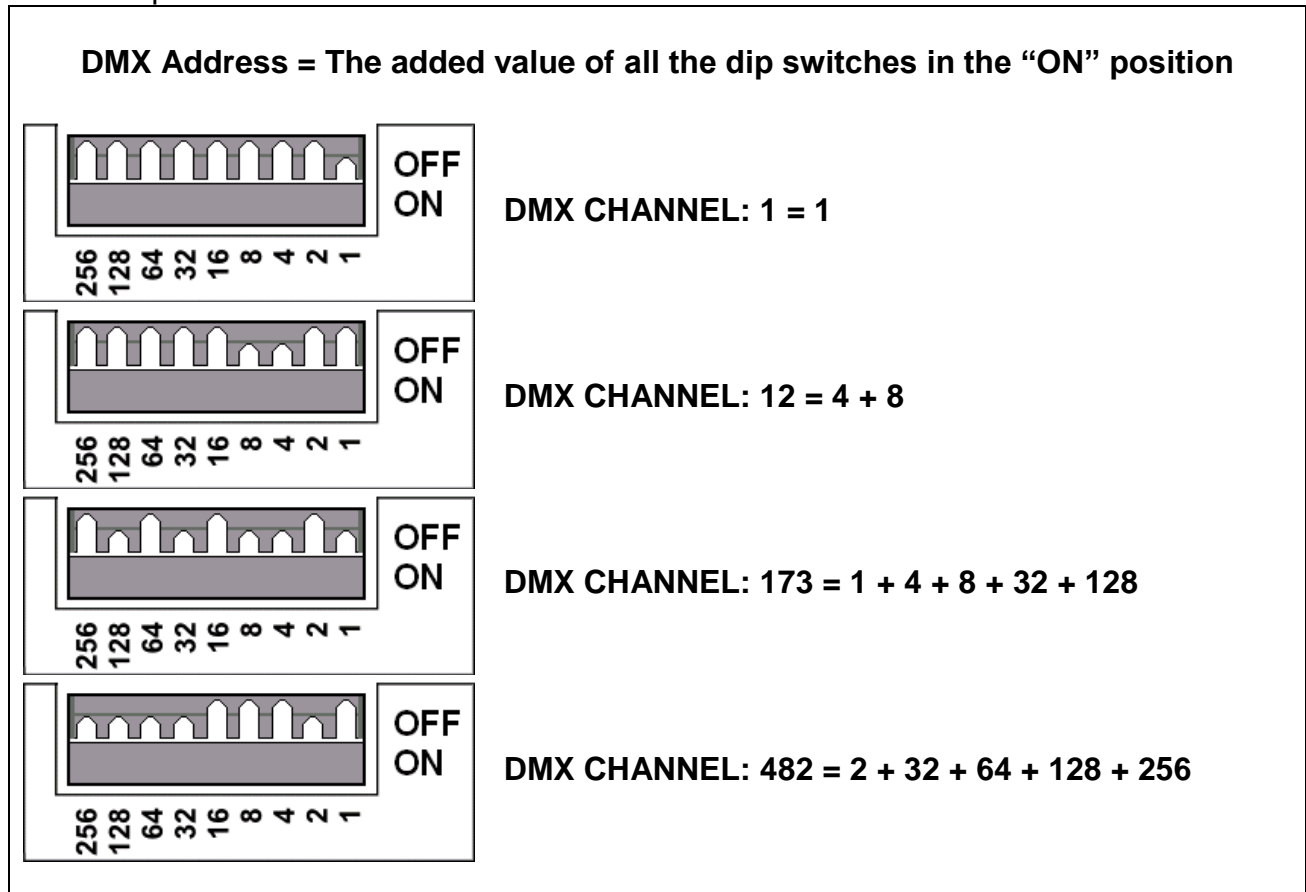

## 5.6 Operation

- With all of the DMX and power cables properly connected and DMX addressed, you may switch the DMX FX-15™ Switch Pack on by increasing the value of the assigned DMX channel to 128-255 (50%-100%).
- Decrease the value of the assigned DMX channel to 0-127 (0%-49%) to turn the DMX FX-15™ Switch Pack off.
- If for any reason the DMX signal is lost (e.g. the DMX console is turned off), the DMX FX-15™ Switch Pack will turn off the power to the attached device.
- It is always recommended to use a DMX line terminator at the end of your DMX run to soak up any residual DMX signal.



## 5.7 Indicator Lights (LED)

- RED / POWER:
  - **ON:** Line voltage present.
  - **OFF:** No line voltage present.
- GREEN / DMX:
  - **ON:** DMX-512 signal present.
  - **OFF:** No DMX-512 signal present.
- BLUE / RELAY:
  - **ON:** The switch is active and line voltage is present at the “POWER OUT” outlet.
  - **OFF:** The switch is inactive and line voltage is not present at the “POWER OUT” outlet.

## 5.8 Troubleshooting

Problem:	Solution:
None of the indicator lights are illuminated.	-Check power.
Indicator lights illuminate, but there is no power to the outlet.	-Check fuse. -Connected device must be turned on.
The power light is blinking.	-Incorrect voltage, unplug immediately.
Power light illuminated, but no DMX light.	-Check DMX signal.
DMX light illuminated, but no Relay light.	-Check DMX address. -The value of the assigned DMX channel must be 128-255 (50%-100%) to operate.

## 6. Technical Data

<b>DMX FX-15™ Switch Pack</b> P/N 250051 (120V) • P/N 250052 (230V)	
Dimensions	4 ¼" x 4 7/16" x 2" (10.8cm x 11.3cm x 5.1cm)
Weight w/ Power Cord	2 lb (0.907kg)
Included Accessories	Power Cord – 120vac: IEC to NEMA 5-15 – 230vac: IEC to Euro, plus universal plug adapter
Operating Temperature	32°F-122°F (0°C-50°C)
DMX Connectors	5 pin XLR
Assignable DMX Address	1 - 511
DMX Channels Used	1
Electrical Supply	120 VAC, 15A, 50/60 Hz 230 VAC, 8A, 50/60 Hz
Fuse	15A – 125 VAC, 5mm x 20mm 8A – 250 VAC, 5mm x 20mm
Limited Warranty	
Rev. 01/14/2015	

## 7. One Year Limited Warranty

**Model:** \_\_\_\_\_ **Purchased on (date):** \_\_\_\_\_

**Serial number:** \_\_\_\_\_ **Purchased from:** \_\_\_\_\_

### **Congratulations!**

You can now look forward to many years of reliable operation and outstanding performance. Thank you for making CITC your personal choice in special effects equipment. Please take a moment to **fill out the top of this warranty**, and then keep it – with the receipt – in a safe place.

If you would like to receive information about specials, sales, and new products, please log on to [www.citcfx.com](http://www.citcfx.com) and click on the “Contact Us” link.

We appreciate your business, and wish to provide you with a quality product that will serve you for many years to come. Once again, thank you for choosing CITC, and enjoy your new entertainment product!

### **LIMITED WARRANTY CONDITIONS**

This limited warranty guarantees to the original purchaser that this product shall be free of defects in material and workmanship, under normal use, for a period of one year from the date of purchase shown on the sales receipt. This warranty covers parts and labor providing the product is returned to CITC in the original shipping carton and packaging. The warranty for electrical is a (90) NINETY DAY limited warranty.

Damage resulting from shipping, accidents, misuse, negligence, unauthorized repairs or modification is not covered by this warranty. Using any fluid other than what is recommended for this machine will void warranty. No liability is accepted for injury or for loss, damage or expense resulting from any interruption whatsoever in the operation of the product or from any consequential loss arising there from. No liability is accepted for normal wear and tear.

We wish to satisfy YOU, our customer, and have implemented many measures to prevent problems and assure customer satisfaction. However, should you need a missing part or have a functional problem with your product, please call:

(888) 786-CITC, from 7:30 am – 4:00 pm (Pacific Time), Monday – Friday, except for holidays. Our customer service department will respond to your problems immediately.

---

Subject to the following conditions, CITC will repair any defect or fault in the unit if it is caused by a proven factory defect within one year of delivery to the end user.

Insignificant deviations of the regular product quality does not guarantee replacement rights, nor do faults or defects caused by water, by generally abnormal environment conditions or Force Majeure:

1. Faulty parts or equipment will be repaired or replaced (manufacturer’s choice) with correct parts. Faulty units must be shipped to CITC at customer’s expense. Call for an RMA# - AN RMA# MUST COME WITH THE UNIT. Payment arrangements for repair must be made before receiving your RMA#, in case the unit is not covered under this limited warranty.
2. Repairs/replacements will only be made with the approval of the customer.

3. Exposure to outside elements voids Warranty. Unit cannot be used outdoors or in wet weather without complete protection against the elements. Even then, high salty or humid conditions will cause instant corrosion of connectors and will void Warranty.
4. The customer loses all rights for limited warranty services if any repairs or adjustments are done to the units by unauthorized persons, and/or if spare parts are used, which are not approved by CITC. The right of limited warranty service is also lost if a fluid other than appropriate CITC fluid has been used or if units are sent in without first emptying the equipment of fluid.
5. Freight costs to and from CITC, when under the limited warranty services, are the responsibility of the customer. Customer must place appropriate insurance on return of product. However, if product is returned due to factory defect within the first year, CITC will cover the cost of returning the repaired unit to the customer.
6. Limited warranty services do not cause an extension of the limited warranty period or the start of a new limited warranty period. The warranty of replaced parts ends with the limited warranty period of the whole unit.
7. Further claims, especially for damages, losses etc. outside the unit are excluded.

**Send unit to:** CITC  
RMA # XXXXXXXX  
1420 80<sup>th</sup> St. SW #D  
Everett, WA 98203



**Tel:** (888) 786-CITC or (425) 776-4950  
**Fax:** (425) 776-5129  
**Website:** [www.citcfx.com](http://www.citcfx.com)  
**E-mail:** [info@citcfx.com](mailto:info@citcfx.com)



**Find us on Facebook!**  
[www.facebook.com/CITCFX](http://www.facebook.com/CITCFX)

July 16, 2015